



PROPER STORAGE AND HANDLING OF GLULAM BEAMS

APA EWS trademarked glued laminated beams (glulam) must be stored properly and handled with care to assure optimum performance. When they leave the mill, glulam beams are often protected with sealants, primers or wrappings that are specified in the order. Care must be taken during loading, unloading and transporting as well as in the yard and on the job site to protect these members from damage.

Sealants, Primers and Wrappings

Sealants applied to the ends of beams help guard against moisture penetration and excessive end grain checking. A coat of sealant should be field applied to the ends of beams (see Figure 1) if they are trimmed to length, dapped or otherwise cut after leaving the mill. See EWS Technical Note S560 for additional information on field cutting of glued laminated timber.

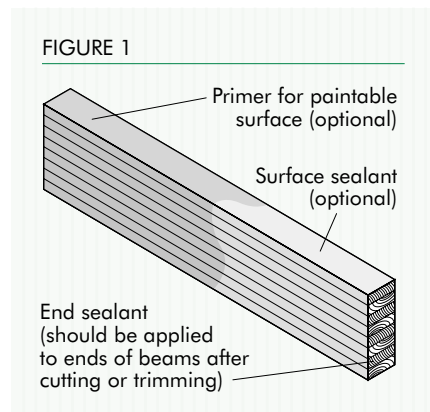

Surface sealants, which can be applied to the top, bottom and sides of beams, resist dirt and moisture intrusion and help control checking and grain raising. Specify a paintable penetrating sealant if beams are to be stained or given a natural finish.

A primer coat also helps protect beams from moisture and soiling and provides a paintable surface for subsequent finishing, if specified.

Water-resistant wrappings are often specified to protect beams from moisture, soiling, and surface scratches during transit and job-site storage. Because

exposure to sunlight can discolor beams, opaque wrappings are recommended.

Beams can be wrapped individually, by bundle or by load tarping. In applications where appearance is especially important, individual wrapping should be left intact until installation to minimize exposure to jobsite conditions.

Loading and Unloading

Glulam beams are commonly loaded and unloaded with fork lifts. For greater stability and handling safety, place the sides of the beams, rather than the bottoms, flat on the forks (see Figure 2). Carrying

FIGURE 2

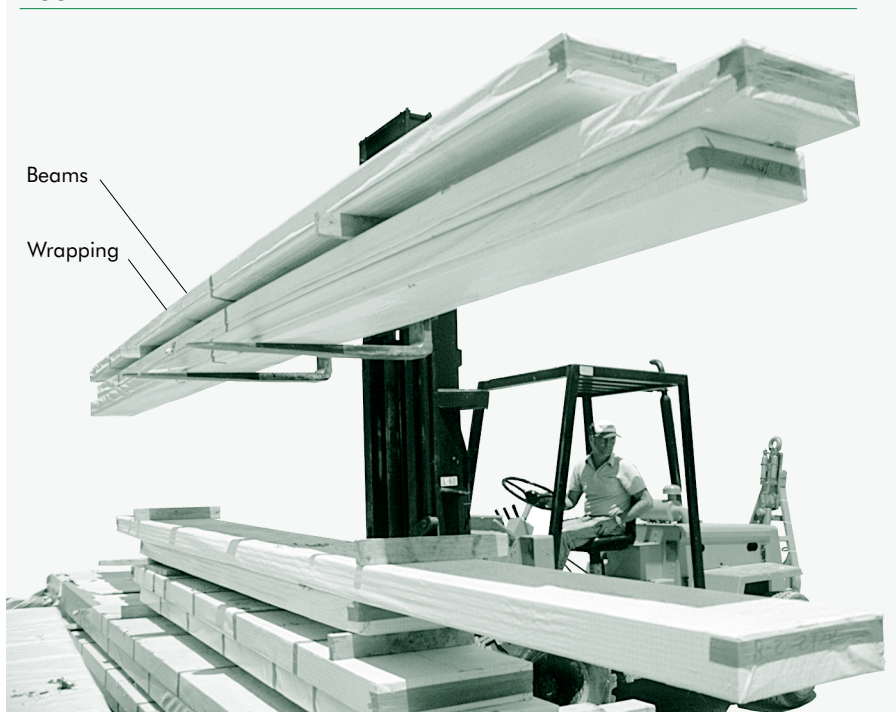

extremely long beams on their sides, however, can cause them to flex excessively. To control flex in these cases, use two or more fork lifts, lifting in unison. If a crane with slings or chokers is used to load or unload beams, provide adequate blocking at all beam edges between the sling and the members to protect corners and edges. Only fabric slings should be used to lift glulam members. Using spreader bars can reduce the likelihood of damage when lifting long beams.

Storage in the Yard

A level, well-drained covered storage site is recommended. Keep beams off the ground using lumber blocking, skids or rack systems as shown in Figures 3 and 4. If the beams are wrapped, the wrapping should be left in place to protect them from moisture, soiling, sunlight, and scratches. For long-term storage, cut slits in the bottom of the wrapping to allow ventilation and drainage of any entrapped moisture (see Figure 3). Proper ventilation and drainage will reduce the likelihood of water damage.

FIGURE 3

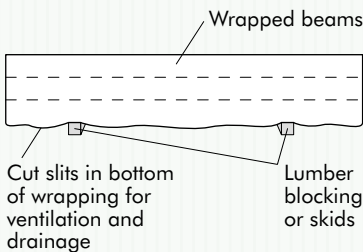

Transportation

Stack beams on lumber blocking or skids when loading them on rail cars or trucks. Beams can rest on their sides or bottoms. Secure the load with straps to keep it from shifting. Protect beam edges with “softeners” or wood blocking when strapping down the load.

Storage at the Job Site

If possible, store glulam under cover to protect the beams from moisture, soiling and sunlight. Place the beams on spaced lumber blocking on level, well-drained ground (see Figure 3). In many instances, the wrappings can be left intact to protect beams until installation. Again, seal ends of beams whenever possible after trimming or cutting. Once beams are installed, allow them to gradually season and adjust to the temperature and moisture conditions of the structure. Do not expose glulam members to rapid changes in moisture and temperature such as may occur from temporary heating units. Such exposure may result in excessive surface checking. See EWS Technical Note R465 for additional information on checking in glued laminated timber.

FIGURE 4

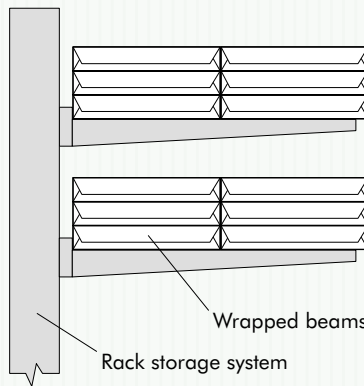

We have field representatives in most major U.S. cities and in Canada who can help answer questions involving APA and APA EWS trademarked products. For additional assistance in specifying engineered wood products or systems, contact us:

APA – THE ENGINEERED WOOD ASSOCIATION HEADQUARTERS

7011 So. 19th St. ■ P.O. Box 11700
Tacoma, Washington 98411-0700
(253) 565-6600 ■ Fax: (253) 565-7265

(International Offices:
Bournemouth, United Kingdom;
Mexico City, Mexico; Tokyo, Japan.)



www.apawood.org

PRODUCT SUPPORT HELP DESK

(253) 620-7400
E-mail Address: help@apawood.org

The product use recommendations in this publication are based on the continuing programs of laboratory testing, product research, and comprehensive field experience of Engineered Wood Systems. However, because EWS has no control over quality of workmanship or the conditions under which engineered wood products are used, it cannot accept responsibility for product performance or designs as actually constructed. Because engineered wood product performance requirements vary geographically, consult your local architect, engineer or design professional to assure compliance with code, construction, and performance requirements.

Form No. EWS R540C
Revised February 2002/0010

