

TECHNICAL NOTE

Effect of Large Diameter Horizontal Holes on the Bending and Shear Properties of Structural Glued Laminated Timber

Number V700B

February 2020

1. Introduction

Structural glued laminated timber (glulam) beams are highly engineered components manufactured from specially selected and positioned lumber laminations of varying strength and stiffness. As most glulam beams are designed for and used in applications where they will be highly stressed under design loads, drilling or notching of glulam should be avoided and never done without a thorough understanding of the effects on the structural integrity of a member. This is specifically addressed in Section R502.8.2 of the 2018 International Residential Code (IRC) as follows (the same wording also appears in Section R802.7.2 of the 2018 IRC):

R502.8.2 Engineered wood products. Cuts, notches and holes bored in trusses, structural composite lumber, structural glue-laminated members, cross-laminated timber members or I-joists are prohibited except where permitted by the manufacturer's recommendations or where the effects of such alterations are specifically considered in the design of the member by a registered design professional.

APA Technical Note, *Field Notching and Drilling of Glued Laminated Timber Beams*, Form S560, provides guidance for notching and drilling on glulam when the end notching and drilling of horizontal through-thickness holes cannot be avoided. For the latter, the guidelines are intended to prescribe the size, number, and location of holes to alleviate the reduction in the structural capacities of the glulam. Those prescriptive requirements are helpful for contractors and builders to minimize the need to re-engineer the glulam structural members due to some small horizontal holes.

However, it is not unusual in the structural design phase or in the field that some horizontal holes exceeding the guidance provided in S560 may become a necessity. This document is intended to provide an analytical tool for those conditions through engineering equations and supplemental hole placement requirements. It should be noted that this document is not intended to supersede the recommendations provided by the manufacturer of the glulam used in the specific construction project.

2. Limitations

- a. The analytical equations provided in this document are limited to horizontal round holes. Rectangular holes are outside the scope of this document.
- b. The diameter of any holes shall not exceed $2d/3$, where d is the glulam depth with $d \leq 24$ inches. When $d > 24$ inches, the maximum hole diameter (D) shall be limited to 16 inches.
- c. The hole placement requirements specified in Section 6 of this document are an integral part of the analytical equations and must be satisfied to maintain the validity of Eqs. 1 through 3.
- d. Eqs. 1 through 3 are applicable to simple-span or multiple-span members that carry uniform and/or concentrated loads.
- e. The glulam shall meet all requirements of ANSI A190.1, *Standard for Wood Products – Structural Glued Laminated Timber*, and ANSI 117, *Standard Specification for Structural Glued Laminated Timber of Softwood Species*, or shall be recognized in a code evaluation report or an APA Product Report®.

3. Effect of Horizontal Holes on the Bending Capacity

The bending capacity of a glulam member with horizontal holes can be estimated at each hole location using Eq. 1. The bending capacity shall meet or exceed the applied moment at each hole location.

$$M_{net} = C_{hole,M} M_{gross} = \left(\frac{S_{net}}{S_{gross}} \right) M_{gross} \quad [1]$$

where

M_{net} = Net bending capacity with holes, lbf-ft,

$C_{hole,M}$ = Hole effect factor on bending capacity = $\frac{S_{net}}{S_{gross}}$

M_{gross} = Gross bending capacity without holes, lbf-ft,

S_{net} = Net section modulus with holes, in.³, and

S_{gross} = Gross section modulus without holes, in.³

4. Effect of Horizontal Holes on the Bending Stiffness

The bending stiffness of a glulam member with horizontal holes can be estimated using Eq. 2. When there are multiple holes in the member, the diameter of the largest hole should be used in Eq. 2. The bending stiffness of the glulam member with holes shall satisfy the deflection limit specified in the building code.

$$(EI)_{net} = C_{hole,EI} (EI)_{gross} = \left(1 - \frac{1.6ND}{L}\right) (EI)_{gross} \quad [2]$$

where

$(EI)_{net}$ = Net bending stiffness with holes, lbf-in.²,

$C_{hole,EI}$ = Hole effect factor on bending stiffness = $\left(1 - \frac{1.6ND}{L}\right)$

$(EI)_{gross}$ = Gross bending stiffness without holes, lbf-in.²,

N = Number of holes (see Note b in Section 6 below),

D = Hole diameter (the largest diameter for multiple holes) $\leq 2d/3$, in. or 16 in., whichever is smaller, and

L = Member span, in.

5. Effect of Horizontal Holes on the Shear Capacity

The shear capacity of a glulam member with horizontal holes can be estimated at each hole location using Eq. 3. The shear capacity shall meet or exceed the applied shear at each hole location.

$$V_{net} = C_{hole,V} V_{gross} = \left(\frac{d-D}{d}\right)^2 V_{gross} \quad [3]$$

where

V_{net} = Net shear capacity with holes, lbf,

$C_{hole,V}$ = Hole effect factor on shear capacity = $\left(\frac{d-D}{d}\right)^2$

V_{gross} = Gross shear capacity without holes, lbf,

d = Glulam depth, in., and

D = Hole diameter $\leq 2d/3$, in. or 16 in., whichever is smaller.

6. Hole Placement Requirements

For the application of Eqs. 1 through 3, the following restrictions apply:

- a. Holes shall be round and neatly cut with a hole saw or a router and template. Holes cut by other means, such as a reciprocating saw, are prohibited.
- b. The number of holes in a given span shall be limited to three or less if the diameters of those holes are all greater than $d/3$. Otherwise, the maximum number of holes in a given span shall not be more than eight, provided that the other requirements of this section are all met.
- c. A cluster of small holes may be analyzed as a single round hole that circumscribes the cluster and meets all other requirements prescribed in this section, as shown in Fig. 1.

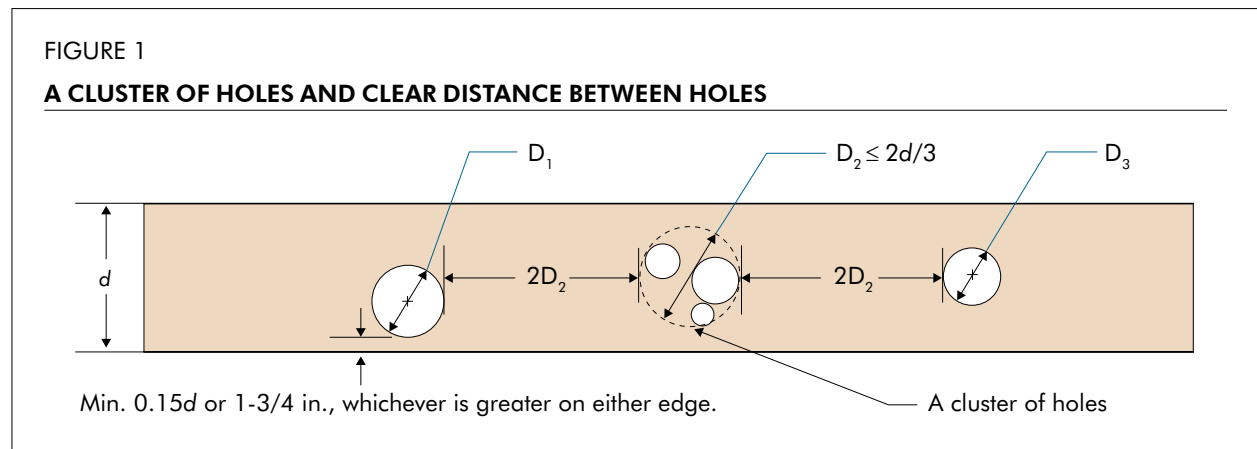

- d. Holes shall not be cut in cantilevers.
- e. The minimum distance along the length of the member between the face of a support and the edge of a hole shall be 6 inches, as shown in Fig. 2.

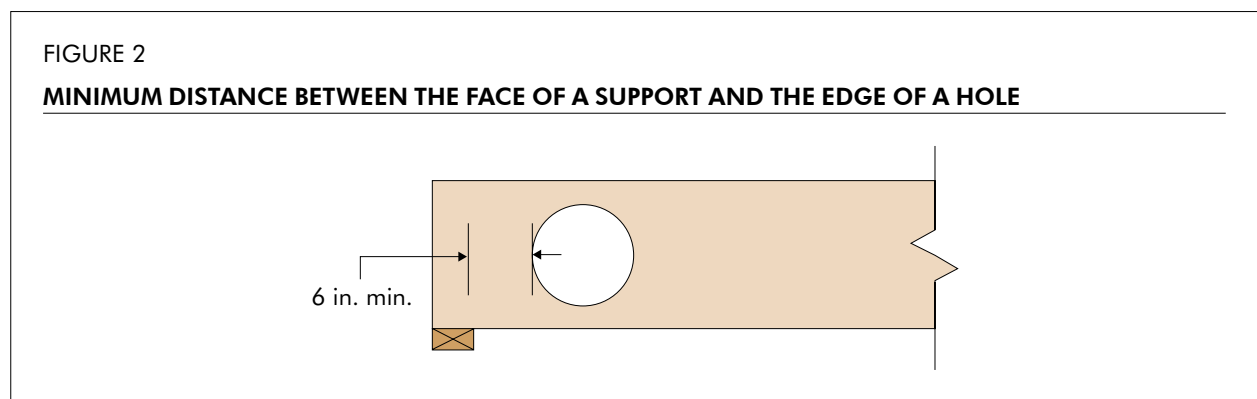

- f. At concentrated loads, the minimum distance along the length of the member between the nearest edge of a hole and the face of a top-load object (e.g., column above), as shown in Fig. 3, or the edge of a side-load object (e.g., face of the LVL member, or hanger), as shown in Figs. 4 and 5, shall be 6 inches except for concentrated loads that are 2,000 lbf or less. The concentrated loads shall not result in a compressive stress that exceeds the allowable edgewise compressive stress perpendicular to grain of the LVL member.

FIGURE 3

MINIMUM DISTANCE ALONG THE LENGTH OF THE MEMBER BETWEEN THE NEAREST EDGE OF A HOLE AND THE FACE OF A TOP-LOAD OBJECT

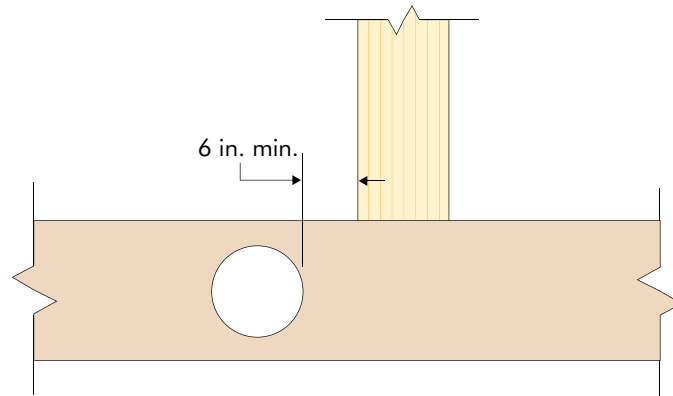

FIGURE 4

MINIMUM DISTANCE ALONG THE LENGTH OF THE MEMBER BETWEEN THE NEAREST EDGE OF A HOLE AND THE EDGE OF A SIDE-LOAD OBJECT

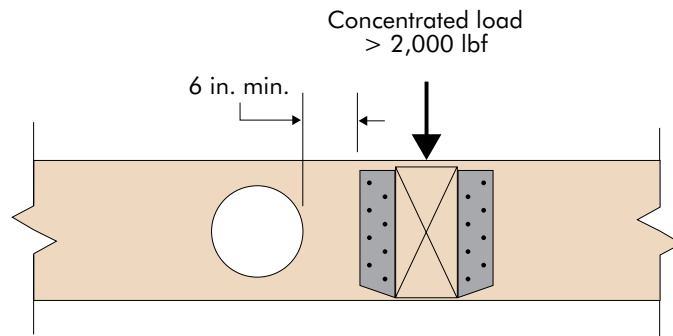
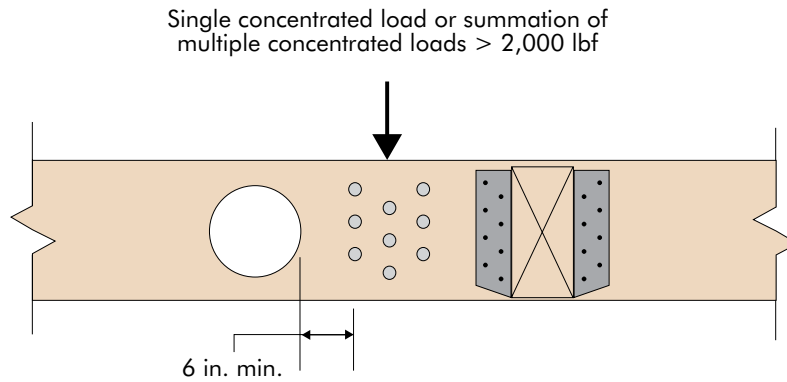

FIGURE 5

MINIMUM DISTANCE ALONG THE LENGTH OF THE MEMBER BETWEEN THE NEAREST EDGE OF A HOLE AND THE EDGE OF A SIDE-LOAD OBJECT



- g. For taper or notch cuts at the end of the member, the minimum distance along the length of the member from the end of the taper or notch cut to the nearest edge of a hole shall be 12 inches, as shown in Fig. 6.

FIGURE 6

MINIMUM DISTANCE FROM THE END OF THE TAPER OR NOTCH CUTS TO THE NEAREST EDGE OF A HOLE

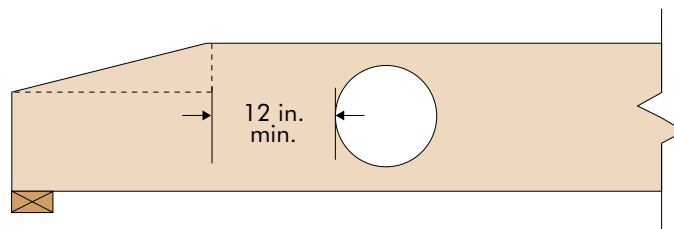

- h. For adjacent holes, the clear distance between holes shall be two hole diameters or larger based on the diameter of the larger hole, as shown in Fig. 1. The clear distance shall be measured along the member length, as opposed to diagonally across the member depth if holes are staggered.
- i. The hole diameter shall not exceed $2d/3$ and the clear distance between the edge of the hole and either edge of the beam shall be at least $0.15d$ or one lamination thickness (typically 1-1/2 inches for Western Species or 1-3/8 inches for Southern Pine), whichever is greater, as shown in Fig. 1.

7. References

- a. APA – The Engineered Wood Association. 2020. *APA Technical Note: Field Notching and Drilling of Glued Laminated Timber Beams*. Form S560. Tacoma, WA.
- b. APA – The Engineered Wood Association. 2015. *American National Standard Specification for Structural Glued Laminated Timber of Softwood Species*. ANSI 117. Tacoma, WA.
- c. APA – The Engineered Wood Association. 2017. *American National Standard for Wood Products – Structural Glued Laminated Timber*. ANSI A190.1. Tacoma, WA.
- d. International Code Council. 2018. *International Building Code*. Country Club Hills, IL.

Effect of Large Diameter Horizontal Holes on the Bending and Shear Properties of Structural Glued Laminated Timber

We have field representatives in many major U.S. cities and in Canada who can help answer questions involving APA trademarked products. For additional assistance in specifying engineered wood products, contact us:

APA HEADQUARTERS

7011 So. 19th St. ■ Tacoma, Washington 98466
(253) 565-6600 ■ Fax: (253) 565-7265

PRODUCT SUPPORT HELP DESK

(253) 620-7400 ■ help@apawood.org

DISCLAIMER

The information contained herein is based on APA – The Engineered Wood Association’s continuing programs of laboratory testing, product research, and comprehensive field experience. Neither APA, nor its members make any warranty, expressed or implied, or assume any legal liability or responsibility for the use, application of, and/or reference to opinions, findings, conclusions, or recommendations included in this publication. Consult your local jurisdiction or design professional to assure compliance with code, construction, and performance requirements. Because APA has no control over quality of workmanship or the conditions under which engineered wood products are used, it cannot accept responsibility for product performance or designs as actually constructed.

Form No. V700B/Revised February 2020

© 2020 APA – The Engineered Wood Association



REPRESENTING THE ENGINEERED WOOD INDUSTRY